

### CONTENTS:

Introduction . . . . .	1
Model Number System . . . . .	1
Safety Information. . . . .	2
Special Information . . . . .	3
Installation. . . . .	3
Maintenance . . . . .	4
Disassembly of Pump. . . . .	5
Assembly of Pump . . . . .	6
Installation of Carbon Graphite Bushings . . . . .	6
Pressure Relief Valve Instructions . . . . .	6
Troubleshooting . . . . .	8
Do's and Don'ts . . . . .	8
Warranty . . . . .	9

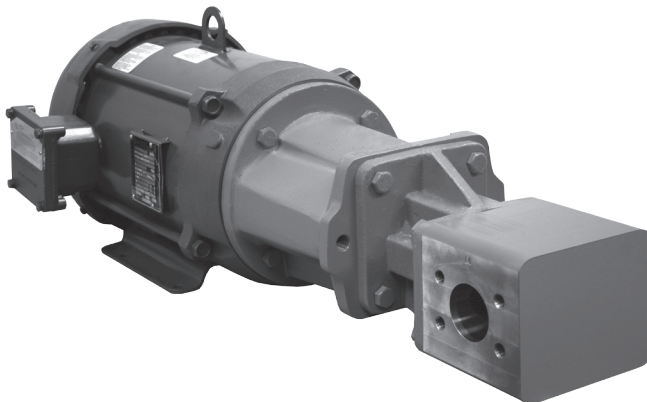

### INTRODUCTION:

The illustrations used in this manual are for identification purposes only and cannot be used for ordering parts. Obtain a parts list from the factory or a Viking representative. Always give the complete name of the part, part number and material with the model number and serial number of the pump when ordering repair parts. The unmounted pump or pump unit model number and serial number are on the nameplate.

### MODEL NUMBER CHART:

UNMOUNTED PUMP		UNITS
LIP SEAL	MECH. SEAL	
SG-1009-G00	SG-41009-G00	Units are designated by the unmounted pump model numbers followed by a letter(s) indicating drive style.  M = Motor, Face Mounted D = Direct Drive R = Viking Speed Reducer P = Commercial Speed Reducer
SG-1009-G0V	SG-41009-G0V	
SG-1009-G10	SG-41009-G10	
SG-1009-G1V	SG-41009-G1V	
SG-1013-G00	SG-41013-G00	
SG-1013-G0V	SG-41013-G0V	
SG-1013-G10	SG-41013-G10	
SG-1013-G1V	SG-41013-G1V	
SG-1026-G00	SG-41026-G00	
SG-1026-G0V	SG-41026-G0V	
SG-1026-G10	SG-41026-G10	
SG-1026-G1V	SG-41026-G1V	
SG-1420-G00	SG-41420-G00	
SG-1420-G0V	SG-41420-G0V	
SG-1420-G10	SG-41420-G10	
SG-1420-G1V	SG-41420-G1V	
SG-1434-G00	SG-41434-G00	
SG-1434-G0V	SG-41434-G0V	
SG-1434-G10	SG-41434-G10	
SG-1434-G1V	SG-41434-G1V	
SG-1456-G00	SG-41456-G00	
SG-1456-G0V	SG-41456-G0V	
SG-1456-G10	SG-41456-G10	
SG-1456-G1V	SG-41456-G1V	

This manual deals only with Series SG-10 and SG-14 External Gear Pumps. Refer to Figures 1 through 3 for general configuration and nomenclature used in this manual. Pump specifications and recommendations are listed in Catalog Section 341.

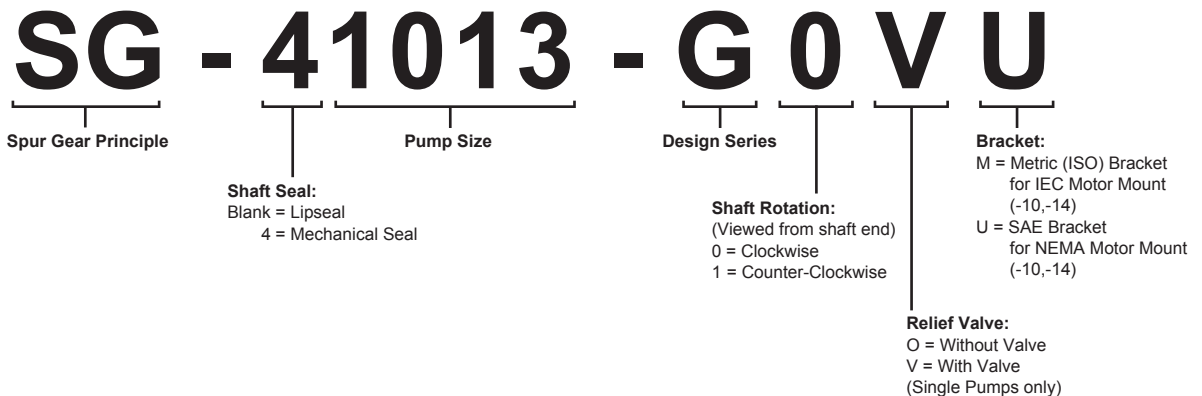

# SAFETY INFORMATION AND INSTRUCTIONS

IMPROPER INSTALLATION, OPERATION OR MAINTENANCE OF PUMP MAY CAUSE SERIOUS INJURY OR DEATH AND/OR RESULT IN DAMAGE TO PUMP AND/OR OTHER EQUIPMENT. VIKING'S WARRANTY DOES NOT COVER FAILURE DUE TO IMPROPER INSTALLATION, OPERATION OR MAINTENANCE.

THIS INFORMATION MUST BE FULLY READ BEFORE BEGINNING INSTALLATION, OPERATION OR MAINTENANCE OF PUMP AND MUST BE KEPT WITH PUMP. PUMP MUST BE INSTALLED, OPERATED AND MAINTAINED ONLY BY SUITABLY TRAINED AND QUALIFIED PERSONS.

THE FOLLOWING SAFETY INSTRUCTIONS MUST BE FOLLOWED AND ADHERED TO AT ALL TIMES.

Symbol Legend :



**Danger** - Failure to follow the indicated instruction may result in serious injury or death.

**WARNING**

**Warning** - In addition to possible serious injury or death, failure to follow the indicated instruction may cause damage to pump and/or other equipment.



**BEFORE** opening any liquid chamber (pumping chamber, reservoir, relief valve adjusting cap fitting, etc.) be sure that :

- Any pressure in the chamber has been completely vented through the suction or discharge lines or other appropriate openings or connections.
- The pump drive system means (motor, turbine, engine, etc.) has been "locked out" or otherwise been made non-operational so that it cannot be started while work is being done on the pump.
- You know what material the pump has been handling, have obtained a material safety data sheet (MSDS) for the material, and understand and follow all precautions appropriate for the safe handling of the material.

**WARNING**

**INSTALL** pressure gauges/sensors next to the pump suction and discharge connections to monitor pressures.



**WARNING**

**USE** extreme caution when lifting the pump. Suitable lifting devices should be used when appropriate. If the pump is mounted on a base plate, the base plate must be used for all lifting purposes. If slings are used for lifting, they must be safely and securely attached. For weight of the pump alone (which does not include the drive and/or base plate) refer to the Viking Pump product catalog.

**DO NOT** attempt to dismantle a pressure relief valve that has not had the spring pressure relieved or is mounted on a pump that is operating.



**BEFORE** operating the pump, be sure all drive guards are in place.



**AVOID** contact with hot areas of the pump and/or drive. Certain operating conditions, temperature control devices (jackets, heat-tracing, etc.), improper installation, improper operation, and improper maintenance can all cause high temperatures on the pump and/or drive.



**DO NOT** operate pump if the suction or discharge piping is not connected.



**DO NOT** place fingers into the pumping chamber or its connection ports or into any part of the drive train if there is **any possibility** of the pump shafts being rotated.



**WARNING**

**DO NOT** exceed the pumps rated pressure, speed, and temperature, or change the system/duty parameters from those the pump was originally supplied, without confirming its suitability for the new service.



**WARNING**

**THE PUMP** must be provided with pressure protection. This may be provided through a relief valve mounted directly on the pump, an in-line pressure relief valve, a torque limiting device, or a rupture disk. If pump rotation may be reversed during operation, pressure protection must be provided on **both** sides of pump. Relief valve adjusting screw caps must always point towards suction side of the pump. If pump rotation is reversed, position of the relief valve must be changed. Pressure relief valves cannot be used to control pump flow or regulate discharge pressure. For additional information, refer to Viking Pump's Technical Service Manual TSM 000 and Engineering Service Bulletin ESB-31.



**WARNING**

**BEFORE** operating the pump, be sure that:

- It is clean and free from debris
- all valves in the suction and discharge pipelines are fully opened.
- All piping connected to the pump is fully supported and correctly aligned with the pump.
- Pump rotation is correct for the desired direction of flow.



**WARNING**

**THE PUMP** must be installed in a manner that allows safe access for routine maintenance and for inspection during operation to check for leakage and monitor pump operation.

## SPECIAL INFORMATION:

### DANGER !

**Before opening any Viking pump liquid chamber (pumping chamber, reservoir, relief valve adjusting cap fitting etc.) Be sure:**

1. That any pressure in the chamber has been completely vented through the suction or discharge lines or other appropriate openings or connections.
2. That the driving means (motor, turbine, engine, etc.) has been "locked out" or made non-operational so that it cannot be started while work is being done on pump.
3. That you know what liquid the pump has been handling and the precautions necessary to safely handle the liquid. Obtain a material safety data sheet (MSDS) for the liquid to be sure these precautions are understood.

**Failure to follow above listed precautionary measures may result in serious injury or death.**

## INSTALLATION:

### GENERAL:

The following items must be considered prior to pump installation:

1. **Location** - locate the pump as close as possible to supply of liquid being pumped. If possible locate pump below liquid supply. Viking pumps are self-priming; but, the better the suction conditions the better the pump will perform.
2. **Accessibility** - pump must be accessible for inspection, maintenance and repair.
3. **Suction/Discharge** - SG Series pumps are designed for clockwise rotation as standard (viewed from end of shaft).

**ROTATION:** Viking external gear pumps can be offered in a clockwise (-G0) or counter clockwise (-G1) rotation. The intended rotation and inlet / outlet port positions are noted on the pump nameplate. Do not run the pump in reverse, or the seal will be exposed to full discharge pressure.

### PRESSURE RELIEF VALVES:

1. Viking pumps are positive displacement pumps and must be provided with some sort of pressure protection. This may be a relief valve mounted directly on the pump, an inline pressure relief valve, a torque limiting device or a rupture disk.
2. Relief valve adjusting screw cap must always point towards suction side of pump.
3. Pressure relief valves cannot be used to control pump flow or regulate discharge pressure.

For additional information on pressure relief valves, refer to Technical Service Manual TSM000 and Engineering Service Bulletin ESB-31.

### MOUNTING:

1. Surfaces pump mounts against must be clean and flat.
2. For NEMA Mount, use SAE Grade 5 or better capscrews to mount pump.  
For IEC Mount, use Class 8.8 or better capscrews to mount pump.
3. Standard SG Series pumps are designed to be used with jaw type couplings that do not induce axial thrust on the pump shaft. If an improper type of coupling is used, internal damage may result.
4. Do not strike or press the pump drive coupling to install. Internal pump damage will result. If the coupling does not slide onto the shaft, inspect the coupling, shaft and key for nicks or burrs and remove.
5. If the pump is to be belt or gear driven, the overhung load option must be specified.
6. Once the pump has been mounted and the coupling installed, it is recommended to put lube oil into the suction port and turn the pump by hand to make sure it turns freely.

### ALIGNMENT:

Check alignment after mounting.

1. If unit has flexible coupling, remove any coupling guards or covers and check alignment of coupling halves. A straight edge (piece of key stock will work) across coupling must rest evenly on both rims at top, bottom and sides. See Figure 1.

### DANGER!

**Before starting the pump, be sure all drive equipment guards are in place.**

**Failure to properly mount guards may result in serious injury or death.**

2. Make final check on alignment after piping is hooked up.

**USE STRAIGHT EDGE. THESE SURFACES MUST BE PARALLEL.**

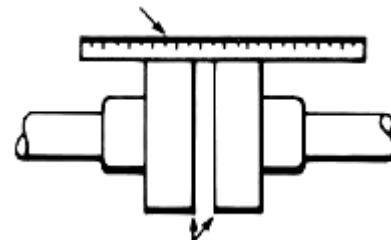

**CHECK WIDTH BETWEEN THESE SURFACES WITH INSIDE CALIPERS OR FEELER GAUGE TO BE CERTAIN THE FACES ARE EQUAL DISTANCE APART AND PARALLEL.**

**FIGURE 1**

## PIPING/HOSE:

The cause of many pumping problems can be traced to suction piping. It should always be as large in diameter and as short in length as possible.

Before starting layout and installation of your piping system, consider the following points:

1. Never use piping smaller than pump port connections. Piping larger in diameter than the port connection is sometimes required to reduce suction losses.
2. Be sure the inside of pipe is clean before installing.
3. When approaching an obstacle to the suction line, go around instead of over it. Going over an obstacle can create an air pocket. Where practical, slope the piping so no air or liquid pockets will be formed. Air pockets in the suction line make it hard for the pump to prime.
4. A strainer on the suction side of the pump should always be considered in any pumping system. The strainer will keep foreign matter from entering the pump. The strainer mesh or perforation size should be large enough so that it does not cause excessive pressure drop, but fine enough to protect the pump. Use of a strainer is particularly important at start up to help clean the system of weld beads, pipe scale and other foreign objects.
5. A pressure relief valve is required in the discharge line. See "Installation, General" page 3 item 4.
6. The pump must not be used to support the piping. Hangers, supports, stands, etc. must carry the weight of the pipes.
7. When fastening piping to the pump do not impose any strain on the pump casing.  
  
"Springing" or "drawing" the piping up to the pump will cause distortion, possible misalignment and probable rapid wear of the pump. Do not use the pump to correct errors in piping layout or assembly.
8. All joints of piping system must be tight; liquid thread sealant will help assure leak free threaded joints. Loose joints result in liquid leaks or suction side leaks. Air leaks make the pump noisy and reduce flow. **CAUTION:** Be careful not to over tighten fittings as this can cause cracked joints. Do not use PTFE tape. Reduced friction makes over tightening very easy and will result in cracked ports. Leaks in the suction line can permit air to be drawn in, and will cause a noisy pump and reduction in capacity.
9. Drive alignment must be checked after piping is hooked up.
10. Provide a pressure relief device in any part of a pump and piping system that can be valved off and, thus, completely isolated. A rise in temperature will cause a liquid to expand. If there is no provision for pressure relief in the closed off section, there is a chance that the pump or piping will rupture.

### **DANGER!**

**Before starting the pump, be sure all drive equipment guards are in place.**

**Failure to properly mount guards may result in serious injury or death.**

## START UP:

**Before pushing "start" button, check the following:**

1. Vacuum and pressure gauges (liquid filled) are mounted on or near the pump. Gauges are the quickest and most accurate way of finding out what is happening in the pump.
2. Pump is correctly aligned.
3. There is no pipe strain on the pump casing.
4. Rotate the pump shaft by hand to be sure it turns freely.
5. Motor has been jogged and is running in the correct direction. Refer to "Installation, General" on page 3.
6. Pressure relief valve is installed properly.
7. Suction piping is connected and tight, and valves are open.
8. Make sure the discharge piping is properly connected and sealed, valves are open, and there is a place for the liquid to go.
9. Make sure all guards are in place.
10. The above checklist is a general guideline to be used prior to starting the pump. Since Viking Pump cannot foresee every application for our product and possible system design, the final responsibility is with the user. The pump must be utilized within the catalog specifications and the pump system must be designed to provide safe working conditions.

The "start" button may now be pushed.

The pump should begin to deliver liquid within 15 seconds! If not, push the stop button. Do not run the pump without liquid flow longer than 30 seconds or the pump may be ruined.

Review Startup steps 1 through 10. Consider what the suction and discharge gauges may indicate. If everything appears in order, re-prime pump. Refer to "Mounting", page 3.

Push the "start" button. If nothing is flowing within 30 seconds, stop the pump. The pump is not a compressor, it will not build up much air pressure. It may be necessary to vent discharge line until liquid begins to flow.

**If pump still does not deliver, consider one or more of the following:**

1. The suction line has air leaks.
2. The end of the suction pipe is not submerged deeply enough in the liquid.
3. The suction lift is too great or the suction piping is too small.
4. Liquid is vaporizing in the suction line before it gets to the pump.

If after consideration of these points, the pump still does not deliver liquid, review all points given under **START UP** and read through the **TROUBLESHOOTING** guide and try again. If pump still will not deliver liquid, contact your Viking Pump supplier.

## MAINTENANCE:

Series SG-10 and SG-14 pumps are designed for long, trouble-free service life under a wide variety of application conditions with a minimum of maintenance. The points listed below will help provide long service life.

**CLEANING PUMP:** Keep pump as clean as possible. This will facilitate inspection, adjustment and repair work.

**STORAGE:** If pump is to be stored, or not used for six months or more, pump must be drained and a coat of light oil must be applied to all internal pump parts. Viking suggests rotating pump shaft by hand one complete revolution every 30 days to circulate the oil. Tighten all pump assembly bolts before putting pump in service after being stored.

**SUGGESTED REPAIR TOOLS:** The following tools must be available to properly repair series SG-10 and SG-14

external gear pumps. These tools are in addition to standard mechanics' tools such as open-end wrenches, pliers, screwdrivers, etc. Most of the items can be obtained from an industrial supply house or automobile tool supplier.

1. Soft headed hammer
2. Snap ring pliers
3. Arbor press
4. Blind bearing puller set

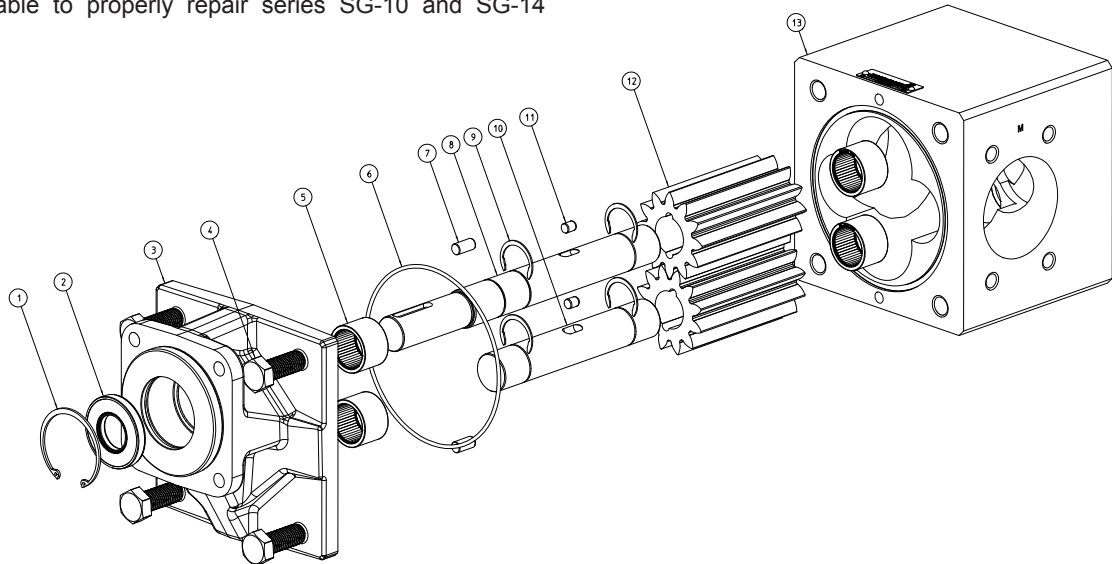

ITEM	NAME OF PART	ITEM	NAME OF PART	ITEM	NAME OF PART
1	External Snap Ring	6	O-ring	11	Gear Pins (2 Required)
2	Lip Seal	7	Alignment Pins (2 Required)	12	Gears (2 Required)
3	Bracket	8	Drive Shaft	13	Casing
4	Cap screws (4 Required)	9	Crescent Snap Rings (4 Required)		
5	Bearings (4 Required)	10	Driven Shaft		

**FIGURE 2**  
**EXPLODED VIEW – MODELS SG-10 AND SG-14 LIP SEAL PUMPS**

### DANGER !

Before opening any Viking pump liquid chamber (pumping chamber, reservoir, relief valve adjusting cap fitting etc.) Be sure:

1. That any pressure in chamber has been completely vented through suction or discharge lines or other appropriate openings or connections.
2. That the driving means (motor, turbine, engine, etc.) has been "locked out" or made

non-operational so that it cannot be started while work is being done on pump.

3. That you know what liquid the pump has been handling and the precautions necessary to safely handle the liquid. Obtain a material safety data sheet (MSDS) for the liquid to be sure these precautions are understood.

Failure to follow above listed precautionary measures may result in serious injury or death.

### DISASSEMBLY:

1. Remove pump from motor or other drive equipment.
2. Mark bracket and casing before disassembly to insure proper reassembly. Remove bracket from pump casing.
3. Remove both shaft assemblies.
4. To remove the gears from the shafts, remove the snap rings. The gears should then slide freely off the shaft.

**NOTE:** There is a small pin located under the gear which can fall out of its groove when the gears are removed.

5. If the bearings or bushings need to be replaced:  
Remove the bearings from the bracket and casing using a Blind Bearing Puller. To remove carbon graphite or silicon carbide bushings, use a cold chisel or punch to break the bushing. Be careful not to damage the bore.
6. Remove the snap ring and lip seal from the pump bracket.

## ASSEMBLY:

1. Be sure to clean the bracket and casing thoroughly. If the bearings were removed, install new pump bearings into each bore using an arbor press. If carbon graphite, Refer to "Installation of Carbon Graphite Bushings" below.

MODELS	BEARING PRESS DEPTH
SG-10 / SG-410	0.060" - 0.080" (1.5 - 2 mm)
SG-14 / SG-414	0.070" - 0.090" (1.8 - 2.3 mm)

2. Install the snap ring and lip seal into the pump bracket.
3. Assemble the shaft / gear assemblies. Install one snap ring onto the shaft. Place the anti rotation pin into its groove on the shaft. Slide the gear over the pin and lock into place using the second snap ring. **NOTE:** Make sure the snap rings do not block the flow path along the gear ID.
4. Coat shaft / gear assemblies with light oil. Place both shafts in the casing with the drive shaft (longer shaft) on the top (nameplate side).
5. Lubricate the casing O-ring and place it in the groove.
6. Place the pump bracket onto the casing. Tighten the capscrews evenly.

MODELS	RECOMMENDED CAPSCREW TORQUE
SG-10 / SG-410	80 ft. lbs. (110 Nm)
SG-14 / SG-414	100 ft. lbs. (140 Nm)

### DANGER!

Before starting the pump, be sure all drive equipment guards are in place.

Failure to properly mount guards may result in serious injury or death.

## INSTALLATION OF CARBON GRAPHITE BUSHINGS:

When installing carbon graphite bushings, extreme care must be taken to prevent breaking. Carbon graphite is a brittle material and is easily cracked. If cracked, the bushing will quickly disintegrate. Using a lubricant and adding a chamfer on the bushing and the mating part will help in installation. The additional precautions listed below must be followed for proper installation.

1. A press must be used for installation.
2. Be certain bushing is started straight.
3. Do not stop pressing operation until bushing is in proper position. Starting and stopping will result in a cracked bushing.
4. Check bushing for cracks after installation.

Carbon graphite bushings with extra interference fits are frequently furnished for high temperature operation. These bushings must be installed by a shrink fit.

1. Heat bracket for idler to 750°F.
2. Install cool bushing with a press.

3. If facilities are not available to reach 750°F. temperature, it is possible to install with 450°F. temperature; however the lower the temperature the greater the possibility of cracking the bushing.

Consult factory with specific questions on high temperature applications.

### DANGER !

Before opening any Viking pump liquid chamber (pumping chamber, reservoir, relief valve adjusting cap fitting etc.) Be sure:

1. That any pressure in chamber has been completely vented through suction or discharge lines or other appropriate openings or connections.
2. That the driving means (motor, turbine, engine, etc.) has been "locked out" or made non- operational so that it cannot be started while work is being done on pump.
3. That you know what liquid the pump has been handling and the precautions necessary to safely handle the liquid. Obtain a material safety data sheet (MSDS) for the liquid to be sure these precautions are understood.

Failure to follow above listed precautionary measures may result in serious injury or death.

## PRESSURE RELIEF VALVE INSTRUCTIONS:

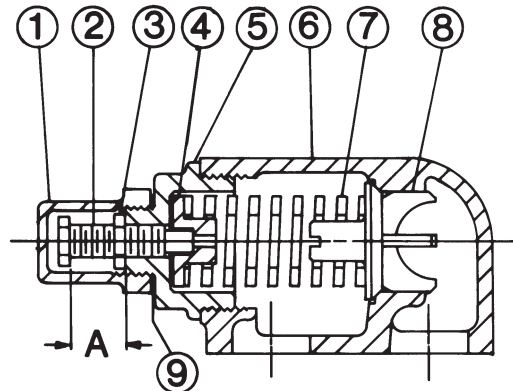

VALVE - LIST OF PARTS			
1.	Valve Cap	6.	Valve Body
2.	Adjusting Screw	7.	Valve Spring
3.	Lock Nut	8.	Poppet
4.	Spring Guide	9.	Cap Gasket
5.	Bonnet		

FIGURE 3

## DANGER !

Before opening any Viking pump liquid chamber (pumping chamber, reservoir, relief valve adjusting cap fitting etc.) Be sure:

1. That any pressure in chamber has been completely vented through suction or discharge lines or other appropriate openings or connections.
2. That the driving means (motor, turbine, engine, etc.) has been "locked out" or made

non- operational so that it cannot be started while work is being done on pump.

3. That you know what liquid the pump has been handling and the precautions necessary to safely handle the liquid. Obtain a material safety data sheet (MSDS) for the liquid to be sure these precautions are understood.

Failure to follow above listed precautionary measures may result in serious injury or death.

## DISASSEMBLY – RELIEF VALVE:

Mark the valve and head before disassembly to ensure proper reassembly.

1. Remove the valve cap.
2. Measure and record the length of extension of the adjusting screw. Refer to "A" on **Figure 3**.
3. Loosen the locknut and back out the adjusting screw until spring pressure is released.
4. Remove the bonnet, spring guide, spring and poppet from the valve body. Clean and inspect all parts for wear or damage and replace as necessary.

## ASSEMBLY – RELIEF VALVE:

Reverse the procedures outlined under **DISASSEMBLY – RELIEF VALVE**. If the valve is removed for repairs, be sure to replace in the original position. The relief valve adjusting screw cap must **always** point towards the suction side of the pump. If the pump rotation is reversed, remove the relief valve and turn end for end.

## PRESSURE ADJUSTMENT:

If a new spring is installed or if pressure setting of pressure relief valve is to be changed from that which the factory has set, the following instructions must be carefully followed.

1. Carefully remove valve cap which covers adjusting screw.  
Loosen locknut which locks adjusting screw so pressure setting will not change during operation of pump.
2. Install a pressure gauge in discharge line for actual adjusting operation.
3. Turn adjusting screw in to increase pressure and out to decrease pressure.
4. With discharge line closed at point beyond pressure gauge, gauge will show maximum pressure valve will allow while pump is in operation.

## TROUBLESHOOTING:

A Viking pump that is properly installed and maintained will give long satisfactory performance.

If trouble does develop, one of the first steps toward finding the difficulty is to install a vacuum gauge in the suction line and a pressure gauge in the discharge line. Readings on these gauges often give a clue on where to start looking for trouble.

## VACUUM GAUGE - SUCTION PORT:

### High vacuum reading would indicate:

1. The suction line is blocked, valve closed, a strainer is plugged or a pinched suction line.
2. The suction line is too small.
3. The liquid is too viscous to flow through the piping.
4. The lift required is too high.

### Low reading would indicate:

1. There may be an air leak in the suction line.
2. The end of the pipe is not in the liquid.
3. The pump is worn.
4. The pump is dry and should be primed.

### Flutter, jumping or erratic reading would indicate:

1. The liquid is vaporizing.
2. Liquid is coming in to the pump in slugs, possibly an air leak or insufficient liquid above the end of the suction pipe.
3. Vibration from cavitation, misalignment, or damaged parts.

## PRESSURE GAUGE - DISCHARGE PORT:

### High reading would indicate:

1. High viscosity and small diameter and/or lengthy discharge line.
2. A downstream strainer or filter is plugged.
3. The pressure relief valve is set too high.
4. Valve in the discharge line partially closed.
5. Line partially plugged from build up on inside of pump, solidified product or foreign object.
6. Liquid in the pipe not up to temperature.

### Low reading would indicate:

1. Pressure relief valve set too low.
2. Pressure relief valve poppet not seating properly.
3. Pump assembly bolts not torqued to specifications.
4. The bypass around pump partially open.
5. Pump is damaged or worn.
6. The pump has too much internal clearance.

**Flutter, jumping or erratic reading would indicate:**

1. Cavitation.
2. Liquid is coming to the pump in slugs.
3. Air leak in the suction line.
4. Vibrating from misalignment or mechanical problems.

**MISCELLANEOUS:****Pump does not pump:**

1. The pump has lost its prime from air leak or low level in tank.
2. The suction lift is too high.
3. Rotating in the wrong direction.
4. The motor does not come up to speed.
5. The strainer is clogged.
6. The bypass valve is open, pressure relief valve set too low or pressure relief valve poppet stuck open.
7. The pump is worn out.
8. Any changes in liquid, system or operation that would help explain the trouble, e.g. new liquid, additional lines or process changes.

**Pump starts, then loses its prime:**

1. The supply tank is empty.
2. The liquid is vaporizing in the suction line.
3. There is an air leak or air pockets in the suction line.
4. The pump is worn out.

**Pump is noisy:**

1. The pump is cavitating (liquid vaporizing in suction line) or being starved (heavy liquid cannot get to pump fast enough). Increase the suction pipe size and/or reduce the length, or decrease the pump speed. If the pump is above the liquid, raise the liquid level closer to the center line of the inlet port. If the liquid is above the pump, increase the head of the liquid.
2. Check alignment.
3. Anchor the base or piping to eliminate vibration.

**Pump not delivering up to capacity:**

1. The pump is starving or cavitating – see Pump is noisy, item 1.
2. The strainer partially clogged.
3. Air leak somewhere in the suction line.
4. Running too slow. Is the motor the correct speed and wired up correctly?
5. Pressure relief valve is set too low, stuck open or has damaged poppet seat.
6. The bypass line around the pump partially opened.
7. The pump is worn out.

**Pump takes too much power (stalls motor):**

1. Liquid is more viscous than the is unit sized to handle.
2. The system pressure relief valve set too high.
3. The pump is misaligned.

**DO'S AND DON'TS:**

Do's and Don'ts for installation, operation and maintenance of Viking pumps to assure safe, long, trouble free operation.

**Installation:**

1. **DO** install the pump as close to supply tank as possible.
2. **DO** leave working space around the pumping unit.
3. **DO** use large, short and straight suction port.
4. **DO** install a strainer in the suction line.
5. **DO** a double check of alignment after unit is mounted and piping is hooked up.
6. **DO** provide pressure relief valve for discharge side of pump.
7. **DO** check for proper rotation.
8. **DO** use piping, hose and fittings rated for maximum system pressure.

**Operation:**

1. **DON'T** run the pump at speeds faster than 1800 RPM.
2. **DON'T** allow the pump to develop pressure higher than those shown in catalog at that size.
3. **DON'T** operate pumps at temperatures above or below limits shown in catalog for model.
4. **DON'T** operate unit without all guards in place.
5. **DON'T** operate pump without pressure relief valve in discharge piping; be sure valve is mounted and set correctly.
6. **DON'T** stick fingers in ports of pump!!! Fingers may be pinched between gears.
7. **DON'T** work on the pump unless driver has been "locked out" so it cannot be started while work is being done on the pump.

**Maintenance:**

1. **DO** record pump model number and serial number and file for further use.
2. **DO** have spare parts, pump or stand by units available, particularly if pump is essential part of key operation process.
3. **DO** obtain, read and keep all maintenance instructions furnished with this pump.

**IMPORTANT:**

In ordering parts for pressure relief valve, always give model number and serial number of pump as it appears on nameplate and name of part wanted. When ordering springs, be sure to give pressure setting desired.

**VIKING  
PUMP**

**TECHNICAL SERVICE MANUAL**  
**EXTERNAL GEAR PUMPS**  
**SERIES SG-10, -14**

SECTION	TSM 340.1
PAGE	9 OF 9
ISSUE	A

**VIKING  
PUMP**

**IDEX  
CORPORATION**

**WARRANTY**

Viking warrants all products manufactured by it to be free from defects in workmanship or material for a period of one (1) year from date of startup, provided that in no event shall this warranty extend more than eighteen (18) months from the date of shipment from Viking. If, during said warranty period, any products sold by Viking prove to be defective in workmanship or material under normal use and service, and if such products are returned to Viking's factory at Cedar Falls, Iowa, transportation charges prepaid, and if the products are found by Viking to be defective in workmanship or material, they will be replaced or repaired free of charge, FOB. Cedar Falls, Iowa.

Viking assumes no liability for consequential damages of any kind and the purchaser by acceptance of delivery assumes all liability for the consequences of the use or misuse of Viking products by the purchaser, his employees or others. Viking will assume no field expense for service or parts unless authorized by it in advance.

Equipment and accessories purchased by Viking from outside sources which are incorporated into any Viking product are warranted only to the extent of and by the original manufacturer's warranty or guarantee, if any.

THIS IS VIKING'S SOLE WARRANTY AND IS IN LIEU OF ALL OTHER WARRANTIES, EXPRESSED OR IMPLIED, WHICH ARE HEREBY EXCLUDED, INCLUDING IN PARTICULAR ALL WARRANTIES OF MERCHANTABILITY OR FITNESS FOR A PARTICULAR PURPOSE. No officer or employee of IDEX Corporation or Viking Pump, Inc. is authorized to alter this warranty.