

CONTENTS

Introduction	1
Special Information	1
Maintenance	2
Disassembly	2
Assembly	5
Pressure Relief Valve Instructions	7

INTRODUCTION

The illustrations used in this manual are for identification purposes only and cannot be used for ordering parts. Obtain a parts list from the factory or a Viking® representative. Always give complete name of part, part number and material with model number and serial number of the pump when ordering repair parts.

UNMOUNTED PUMP		UNITS
PACKED	MECH. SEAL	
H724	H4724	Units are designated by the unmounted pump model numbers followed by a letter indicating drive style. V = V-Belt D = Direct Connected R = Viking Speed Reducer P = Commercial Speed Reducer
HL724	HL4724	
K724	K4724	
KK724	KK4724	
L724	L4724	
LQ724	LQ4724	
LL724	LL4724	

This bulletin deals exclusively with Series 724 and 4724 Heavy Duty Bracket Mounted Stainless Steel Pumps. Refer to Figures 1 through 12 for general configuration and nomenclature used in this bulletin.



FIGURE 1 - UNMOUNTED PUMP

SPECIAL INFORMATION

DANGER !

Before opening any Viking pump liquid chamber (pumping chamber, reservoir, relief valve adjusting cap fitting, etc.) Be sure:

1. That any pressure in the chamber has been completely vented through the suction or discharge lines or other appropriate openings or connections.
2. That the driving means (motor, turbine, engine, etc.) has been "locked out" or made non-operational so that it cannot be started while work is being done on pump.
3. That you know what liquid the pump has been handling and the precautions necessary to safely handle the liquid. Obtain a material safety data sheet (MSDS) for the liquid to be sure these precautions are understood.

Failure to follow above listed precautionary measures may result in serious injury or death.

ROTATION: Viking pumps operate equally well in a clockwise or counterclockwise rotation. Shaft rotation determines which port is suction and which is discharge. Port in area where pumping elements (gear teeth) come out of mesh is suction port.

PRESSURE RELIEF VALVES:

1. Viking pumps are positive displacement pumps and must be provided with some sort of pressure protection. This may be a relief valve mounted directly on the pump, an inline pressure relief valve, a torque limiting device or a rupture disk.
2. There are relief valve options available on those pump models designed to accept a relief valve. Options may include a return to tank relief valve and a jacketed relief valve. Pumps equipped with a jacketed head plate are not available with a relief valve.

SAFETY INFORMATION AND INSTRUCTIONS

IMPROPER INSTALLATION, OPERATION OR MAINTENANCE OF PUMP MAY CAUSE SERIOUS INJURY OR DEATH AND/OR RESULT IN DAMAGE TO PUMP AND/OR OTHER EQUIPMENT. VIKING'S WARRANTY DOES NOT COVER FAILURE DUE TO IMPROPER INSTALLATION, OPERATION OR MAINTENANCE.

THIS INFORMATION MUST BE FULLY READ BEFORE BEGINNING INSTALLATION, OPERATION OR MAINTENANCE OF PUMP AND MUST BE KEPT WITH PUMP. PUMP MUST BE INSTALLED, OPERATED AND MAINTAINED ONLY BY SUITABLY TRAINED AND QUALIFIED PERSONS.

THE FOLLOWING SAFETY INSTRUCTIONS MUST BE FOLLOWED AND ADHERED TO AT ALL TIMES.

Symbol Legend :



Danger - Failure to follow the indicated instruction may result in serious injury or death.

WARNING

Warning - In addition to possible serious injury or death, failure to follow the indicated instruction may cause damage to pump and/or other equipment.



BEFORE opening any liquid chamber (pumping chamber, reservoir, relief valve adjusting cap fitting, etc.) be sure that :

- Any pressure in the chamber has been completely vented through the suction or discharge lines or other appropriate openings or connections.
- The pump drive system means (motor, turbine, engine, etc.) has been "locked out" or otherwise been made non-operational so that it cannot be started while work is being done on the pump.
- You know what material the pump has been handling, have obtained a material safety data sheet (MSDS) for the material, and understand and follow all precautions appropriate for the safe handling of the material.

WARNING

INSTALL pressure gauges/sensors next to the pump suction and discharge connections to monitor pressures.



WARNING

USE extreme caution when lifting the pump. Suitable lifting devices should be used when appropriate. Lifting eyes installed on the pump must be used **only** to lift the pump, **not** the pump with drive and/or base plate. If the pump is mounted on a base plate, the base plate must be used for all lifting purposes. If slings are used for lifting, they must be safely and securely attached. For weight of the pump alone (which does not include the drive and/or base plate) refer to the Viking Pump product catalog.



BEFORE operating the pump, be sure all drive guards are in place.



DO NOT attempt to dismantle a pressure relief valve that has not had the spring pressure relieved or is mounted on a pump that is operating.



DO NOT operate pump if the suction or discharge piping is not connected.



AVOID contact with hot areas of the pump and/or drive. Certain operating conditions, temperature control devices (jackets, heat-tracing, etc.), improper installation, improper operation, and improper maintenance can all cause high temperatures on the pump and/or drive.



DO NOT place fingers into the pumping chamber or its connection ports or into any part of the drive train if there is **any possibility** of the pump shafts being rotated.



WARNING

THE PUMP must be provided with pressure protection. This may be provided through a relief valve mounted directly on the pump, an in-line pressure relief valve, a torque limiting device, or a rupture disk. If pump rotation may be reversed during operation, pressure protection must be provided on **both** sides of pump. Relief valve adjusting screw caps must always point towards suction side of the pump. If pump rotation is reversed, position of the relief valve must be changed. Pressure relief valves cannot be used to control pump flow or regulate discharge pressure. For additional information, refer to Viking Pump's Technical Service Manual TSM 000 and Engineering Service Bulletin ESB-31.

WARNING

DO NOT exceed the pumps rated pressure, speed, and temperature, or change the system/duty parameters from those the pump was originally supplied, without confirming its suitability for the new service.



WARNING

BEFORE operating the pump, be sure that:

- It is clean and free from debris
- all valves in the suction and discharge pipelines are fully opened.
- All piping connected to the pump is fully supported and correctly aligned with the pump.
- Pump rotation is correct for the desired direction of flow.



WARNING

THE PUMP must be installed in a matter that allows safe access for routine maintenance and for inspection during operation to check for leakage and monitor pump operation.

SPECIAL INFORMATION

3. If pump rotation is reversed during operation, pressure protection must be provided on **both** sides of pump.
4. Relief valve adjusting screw cap must **always** point towards suction side of pump. If pump rotation is reversed, remove pressure relief valve and turn end for end. **Refer to Figure 1.**
5. Pressure relief valves should not be used to control pump flow or regulate discharge pressure.

For additional information on pressure relief valves, **Refer to Technical Service Manual TSM000 and Engineering Service Bulletin ESB-31.**

MAINTENANCE

Series 724 and 4724 pumps are designed for long, trouble-free service life under a wide variety of application conditions with a minimum of maintenance, however, the following should be considered.

1. **LUBRICATION** - Periodic external lubrication should be applied slowly with a hand gun at all lubrication fittings provided. A good quality of general purpose grease is satisfactory in the majority of cases, however, applications involving very high or low temperatures may require other types of lubricants. Suggested frequency of lubrication is once every 500 hours of operation. Do not over-grease. Consult the factory if you have specific lubrication questions.
2. **PACKING ADJUSTMENT** - New packed pumps, (Series 724) generally require some initial packing adjustment to control leakage as packing "runs-in". Make initial packing adjustments carefully and do not over tighten the packing gland. After initial adjustment occasional inspection will reveal the need for packing gland adjustment and/or replacement of the packing. See instructions in **DISASSEMBLY** and **ASSEMBLY** regarding repacking the pump.
3. **END CLEARANCE ADJUSTMENT** - After long term operation it is sometimes possible to improve the performance of the pump, without major repair, through adjustment of end clearance of the pump. Refer to instructions under **ASSEMBLY** of the pump for information regarding this procedure.
4. **CLEANING THE PUMP** - It is good practice to keep the pump as clean as possible. This will facilitate inspection, adjustment and repair work and help prevent omission of lubrication to fittings covered or hidden with dirt.
5. **STORAGE** - If the pump is to be stored or not used for any appreciable length of time it should be drained and a light coat of non-detergent SAE 30 weight oil must be applied to all internal pump parts. Lubricate fittings and apply grease to pump shaft extension. Viking suggests rotating pump shaft by hand one complete revolution every 30 days to circulate the oil.

SUGGESTED REPAIR TOOLS: The following tools must be available to properly repair Series 724 and 4724 pumps. These tools are in addition to standard mechanics' tools such as open end wrenches, pliers, screw drivers, etc. Most of the items can be obtained from an industrial supply house.

1. Soft Headed hammer
2. Allen wrenches (some mechanical seals and set collars)
3. Packing hooks, flexible (packed pumps)
H, HL - 1/4" (2-810-049-999)
K and up - 3/8" and larger (2-810-042-999)
4. Mechanical seal installation sleeve
5. Bearing locknut spanner wrench (2-810-044-375)
6. Spanner wrench, adjustable pin type for use on double end caps (2-810-008-375)
7. Brass bar
8. Arbor press

DISASSEMBLY

DANGER !

Before opening any Viking pump liquid chamber (pumping chamber, reservoir, relief valve adjusting cap fitting, etc.) Be sure:

1. **That any pressure in the chamber has been completely vented through the suction or discharge lines or other appropriate openings or connections.**
2. **That the driving means (motor, turbine, engine, etc.) has been "locked out" or made non-operational so that it cannot be started while work is being done on pump.**
3. **That you know what liquid the pump has been handling and the precautions necessary to safely handle the liquid. Obtain a material safety data sheet (MSDS) for the liquid to be sure these precautions are understood.**

Failure to follow above listed precautionary measures may result in serious injury or death.

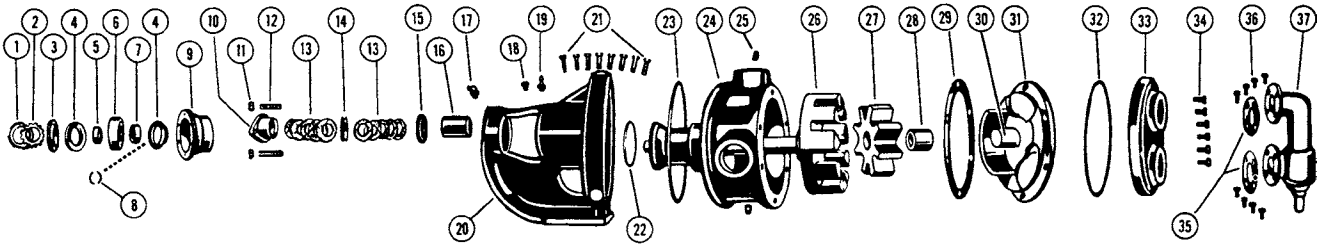

FIGURE 2 - EXPLODED VIEW SERIES 724

ITEM	NAME OF PART	ITEM	NAME OF PART	ITEM	NAME OF PART
1	Locknut	14	Lantern Ring	27	Idler and Bushing Assembly
2	Lockwasher	15	Packing Retainer Washer	28	Idler Bushing
3	End Cap for Bearing Housing	16	Casing Bushing	29	Head Gasket
4	Lipseal Bearing Housing	17	Grease Fitting (Angle)	30	Idler Pin
5	Bearing Spacer Collar	18	Pressure Relief Plug	31	Head and Idler Pin Assembly
6	Ball Bearing	19	Grease Fitting	32	O-ring for Jacket Head Plate
7	Bearing Spacer Collar, Recessed	20	Bracket	33	Jacket Head Plate
8	Half Round Rings	21	Capscrews for Bracket	34	Capscrews for Head
9	Bearing Housing with Setscrews	22	O-ring for Casing Stem	35	Relief Valve Gaskets
10	Packing Gland	23	Back Flange O-ring	36	Capscrews for Valve
11	Packing Gland Nut	24	Casing	37	Internal Relief Valve
12	Packing Gland Capscrew (Studs on Q & M)	25	Pipe Plug		
13	Packing	26	Rotor and Shaft Assembly		

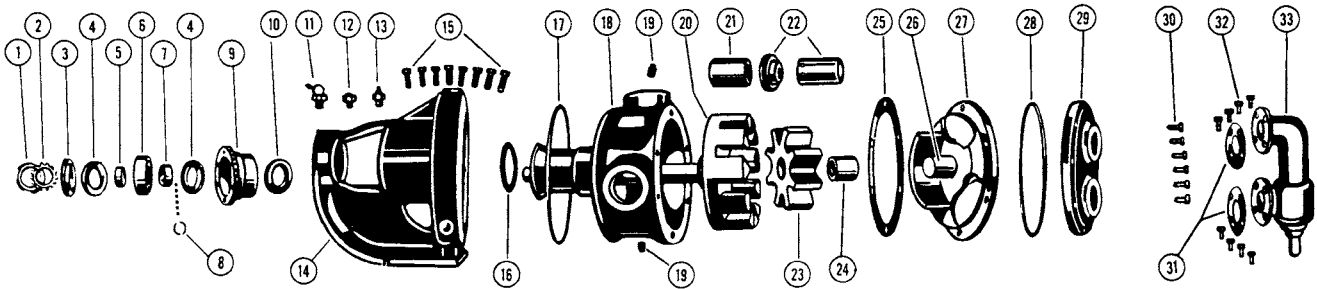

FIGURE 3 - EXPLODED VIEW SERIES 4724

ITEM	NAME OF PART	ITEM	NAME OF PART	ITEM	NAME OF PART
1	Locknut	12	Pressure Relief Plug	23	Idler and Bushing Assembly
2	Lockwasher	13	Grease Fitting	24	Idler Bushing
3	End Cap for Bearing Housing	14	Bracket	25	Head Gasket
4	Lipseal Bearing Housing	15	Capscrews for Bracket	26	Idler Pin
5	Bearing Spacer Collar	16	O-ring for Casing Stem	27	Head and Idler Pin Assembly
6	Ball Bearing	17	Back Flange O-ring	28	O-ring for Jacket Head Plate
7	Bearing Spacer Collar, Recessed	18	Casing	29	Jacket Head Plate
8	Half Round Rings	19	Pipe Plug	30	Capscrews for Head
9	Bearing Housing with Setscrews	20	Rotor and Shaft Assembly	31	Relief Valve Gaskets
10	Lipseal for Seal Chamber	21	Casing Bushing	32	Capscrews for Valve
11	Grease Fitting (Angle)	22	Mechanical Seal	33	Internal Relief Valve

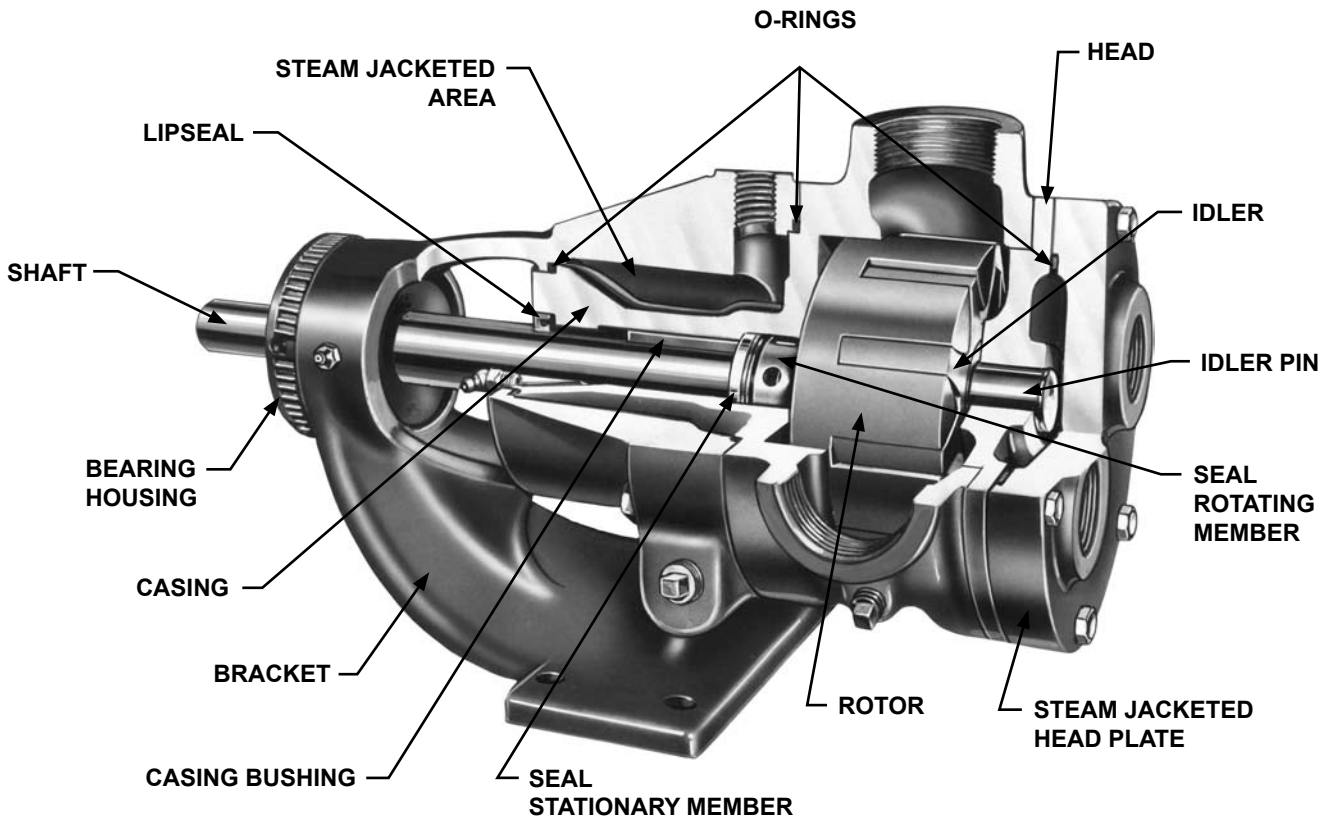

FIGURE 4

DISASSEMBLY

1. Remove the head from the pump.

CAUTION: DO NOT ALLOW THE IDLER TO FALL FROM THE IDLER PIN. Tilting the head up as it is removed will prevent this occurrence. Avoid damaging the head gasket if possible. If pump is furnished with a relief valve it need not be removed from head or disassembled at this point. (See page 6 for **PRESSURE RELIEF VALVE INSTRUCTIONS**). If the pump has a steam jacket head plate, this plate will separate from the head when the head is removed from the pump. The compression O-ring between the head and the jacket head plate should be removed and the gasket surfaces on the above parts cleaned.

Note: These pumps also have a steam jacket feature incorporated into the casing and bracket assembly. To avoid destroying the sealing on this steam jacket the casing should not be removed from the mounting bracket when the pump is disassembled for maintenance. If the pump is equipped with a jacketed head plate, disassembly will probably require replacement of the O-ring between the pump head and jacket head plate. These O-rings should be carried as spare parts for pumps thus equipped.

2. Remove the idler and bushing assembly from the idler pin. Replace all excessively worn parts. See **CAUTION** about replacement of carbon bushings in Step 12.
3. **NOTE:** A piece of wood or brass inserted between the rotor teeth and into the casing port will prevent the shaft from turning. Bend up tang on lockwasher and, using a spanner wrench, remove the lockwasher and locknut.
4. Loosen packing gland nuts on series 724 pumps. Drive the shaft forward approximately 0.5 inch and inspect for presence of a pair of half round rings under the inner bearing spacer collar (K-LL only). If present, these rings must be removed before the rotor and shaft can be removed from the pump.
5. Carefully remove the rotor and shaft assembly from the pump. **NOTE:** Avoid damaging the bracket bushing. The rotary portion of the mechanical seal will usually come out with the shaft on series 4724 pumps. Remove the stationary seal seat from the bracket counterbore. Replace rotor and shaft assembly if excessively worn.

6. Loosen the radial set screws in the bearing housing flange that locks the end cap in place and using a spanner wrench, remove the end cap, lipseal and bearing spacer collar.
7. Remove the 2-row ball bearing and inner spacer collar from bearing housing, wash and inspect bearing for wear or damage and replace, if necessary.
8. Loosen two axial set screws in bearing housing flange and remove housing from bracket. Examine lipseals in end cap and bearing housing and replace with lips facing as shown in **Figure 5** if not in first class condition.
9. On 4724 series pumps, inspect the lipseal in the casing and replace if necessary. This lipseal must be removed if replacement of the casing bushing is necessary. See Step 12.
10. If it is deemed necessary to replace bracket bushing and/or repack series 724 pumps, remove packing gland nuts, old packing and lantern ring and packing retainer washer. See Step 12.
11. Examine casing for excessive wear and replace if necessary.
12. The casing bushing should be inspected for wear and replaced if necessary. See Steps 9 and 10. If it is necessary to install a new carbon graphite bushing, extreme care should be taken to prevent breaking, as it is a brittle material and easily cracked. If cracked these bushings will quickly disintegrate. An arbor press should always be used in installing carbon graphite bushings. Be sure the bushing is started straight. **CAUTION: DO NOT STOP** the pressing operation until the bushing is in proper position. Starting and stopping this operation may result in a bushing crack. Check bushings for cracks after installation. Carbon graphite bushings with extra interference fits are frequently furnished for high temperature operation. Consult Factory. For additional information on high temperature applications, see Engineering Service Bulletin ESB-3.
13. Mechanical Seal (Series 4724): If the mechanical seal in your pump ever fails, it can be easily replaced with a new seal. There are two basic parts to this seal. They are the rotary member and stationary seat (**See Figure 4**). Loosen the set screws holding the rotary member on the shaft. Remove the rotary member from the shaft and the stationary seal seat from the casing. The principle of the mechanical seal is the contact between the rotary and stationary members. These parts are lapped to a high finish and their sealing effectiveness depends upon complete contact.

ASSEMBLY

1. Installing new seal (Series 4724): The seal is simple to install and good performance will result if care is taken during installation. (**See Figure 4**) for parts identification. **NOTE:** Never touch the sealing faces with anything except the fingers or a clean cloth. Clean the rotor hub and casing seal housing, making sure both are free from dirt and grit. Coat the outside diameter of the seal seat and the inside diameter of the seal housing bore with light oil. Start the seal seat in the seal counterbore. Be sure the seat anchor pins are aligned so as to engage the slots in the end of the casing bushing as in **Figure 6**. Using a cardboard cushion to protect the lapped face of the seal seat, tap the seat assembly to the bottom of the seal counterbore with a wooden ram and a light hammer. (Factory installation is accomplished with a special arbor. It has a major diameter which covers the entire seat face and has an extension through the seat which pilots in the casing bushing). Place the tapered sleeve (furnished with replacement seals, H-LL sizes) on shaft as in **Figure 7**. Coat the inside of the rotary member and the outside of the tapered sleeve with the light oil. Place rotary member on the shaft, over the sleeve and against the hub of the rotor. (**See Figure 8**).

Remove the Tapered sleeve. Tighten the setscrew(s) in the rotary member. Some seals may be equipped with installation clips. These must be removed after seal is placed on the proper diameter portion of the shaft.

Flush the sealing faces of both the rotary member and stationary member with oil just before installing rotor and shaft.

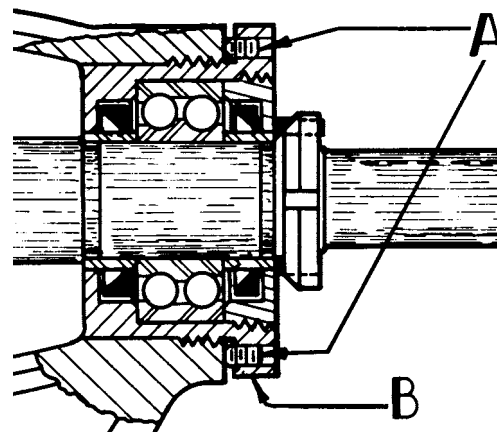

FIGURE 5

2. Be sure shaft is free from burrs and foreign particles that might damage the casing bushing. Install the rotor and shaft. Place the end of the shaft in the casing bushing and turn from right to left slowly, pushing until the ends of the rotor teeth are just below the face of the casing. Refill the casing lubrication chamber with multipurpose grease and place the tapered sleeve in the lipseal for seal chamber as shown in Figure 9. Remove the tapered sleeve from the shaft (Series 4724).

3. On Series 724, pumps replace the packing retainer washer and pack the pump. It is good practice to install a set of new packing. The pump should be packed with a packing suitable for the liquid being pumped.

NOTE: If the pump has a lantern ring it must be located below the grease fitting opening. Install and seat each ring one at a time, staggering the ring joints from one side of the shaft to the other. Lubricate the packing rings with oil, grease or graphite to aid in assembly. A length of pipe or tubing will facilitate installation and seating of the packing rings.

4. Install the packing gland, studs and nuts. Back the rotor and shaft out of the casing just far enough to insert the packing gland through the side opening on the bracket and over the end of the shaft. This gland cannot be assembled over the end of the shaft when in place. Push the rotor and shaft back into place. Make sure the gland is installed square and tighten nuts wrench-tight, back off and retighten to a finger tight condition.

5. Place a head gasket on the head. The normal amount used on all sizes is one .015" gasket.

6. Place the idler and bushing assembly on the idler pin and install the head and idler on the pump. If the pump has a jacketed head plate it will be desirable to use a new O-ring. On these pumps tighten the capscrew until metal to metal contact is made at the joint between the head and the jacket plate. Tilt the top of the head away from the pump slightly until the crescent enters the inside diameter of the rotor and rotate the idler until its teeth mesh with the rotor teeth.

7. Place the bearing collar on the shaft as far as it will go. Replace the half round rings if furnished with the pump.

8. Install the bearing housing and lipseal in the bracket.

9. Pack the ball bearing with grease, place on the shaft and push or drive into place in the bearing housing.

10. Turn the end cap (with lipseal and bearing collar inside) into the bearing housing until tight against the bearing. Lock in place with the setscrews in the outside diameter of the bearing housing.

11. **NOTE:** A piece of brass or wood inserted through the port opening between the rotor teeth will keep the shaft from turning. Install lockwasher and locknut on shaft, tighten locknut and bend down tang of lockwasher into slot of locknut.

12. Adjust pump end clearance, following procedures listed under, "Thrust Bearing Adjustment."

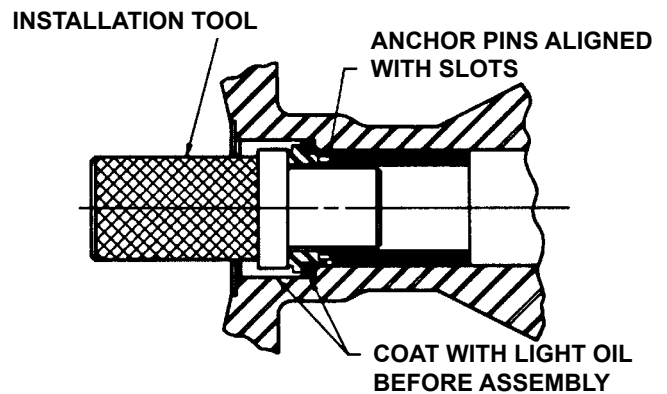

FIGURE 6

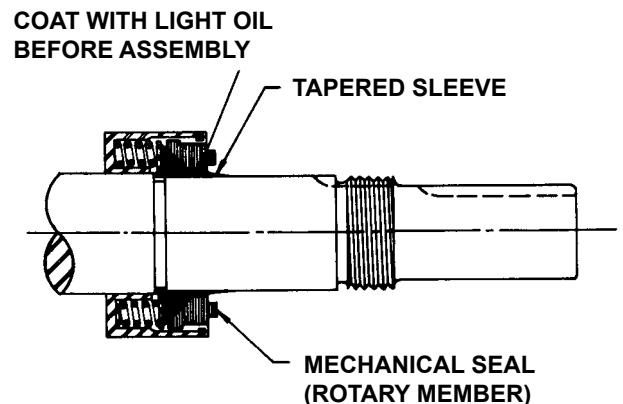

FIGURE 7

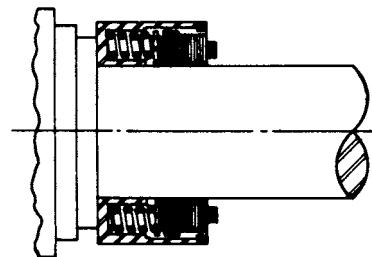

FIGURE 8

DANGER !

Before starting pump, be sure all drive equipment guards are in place.

Failure to properly mount guards may result in serious injury or death.

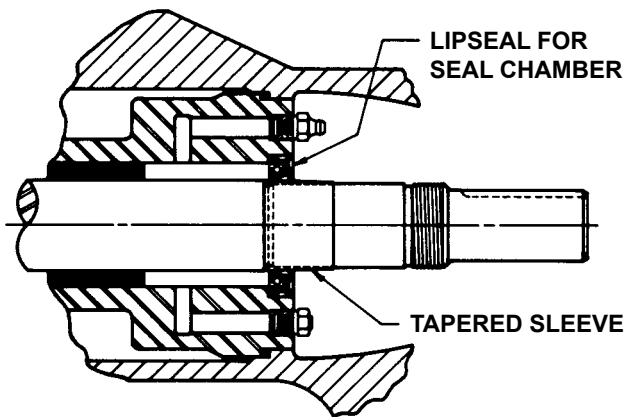

FIGURE 9

THRUST BEARING ADJUSTMENT

(See Figure 10)

1. Loosen the two set screws "A" in the outer face of the bearing housing "B" and turn this thrust bearing assembly "B" clockwise until it can no longer be turned by hand. Back off counterclockwise only until the rotor shaft can be turned by hand with a slight noticeable drag.
2. For standard end clearance, back off the thrust bearing assembly "B" the required number of notches or an equivalent length measured on the outside of the bearing housing. See the following table.

End Clearance	PUMP SIZE	TURN BEARING HOUSING C.C.W. NO. OF NOTCHES OR LENGTH ON O.D., INCHES	
		NO. OF NOTCHES	LENGTH ON O.D., INCHES
.005"	H, HL	2.5	0.6" or 5/8"
.008"	K, KK, LQ & LL	5.5	0.35" or 1-3/8"

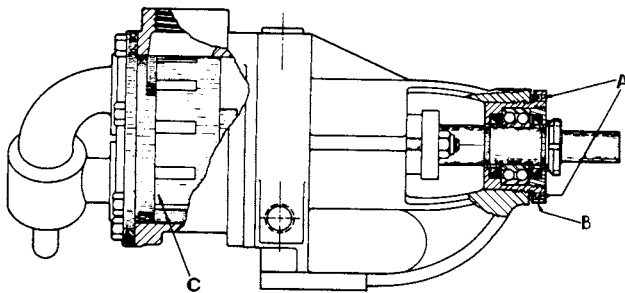

FIGURE 10

3. Tighten the two self locking type "Allen" set screws "A," in the outboard face of the bearing housing, with equal force against the bracket. Your pump is now set with standard end clearances and locked. **NOTE:** Be sure the shaft can rotate freely. If not, back off additional notches and check again.

4. High viscosity and high temperature liquids require additional end clearances. The amount of extra end clearance depends on the viscosity or temperature of the liquid pumped. For specific recommendations, consult the factory. Each additional notch (or each 1/4") on the outside diameter of the bearing housing is equivalent to an extra end clearance of .002" on H & HL size pumps; and .0015" on K, KK, L, LQ and LL pumps.

PRESSURE RELIEF VALVE INSTRUCTIONS

1. Remove valve cap.
2. Measure and record the length of extension of the adjusting screw, **See (A) Figure 11.**
3. Loosen the lock nut and back out adjusting screw until spring pressure is released.
4. Remove bonnet, spring guide, spring and poppet from valve body. Clean and inspect all parts for wear or damage and repair or replace as necessary.

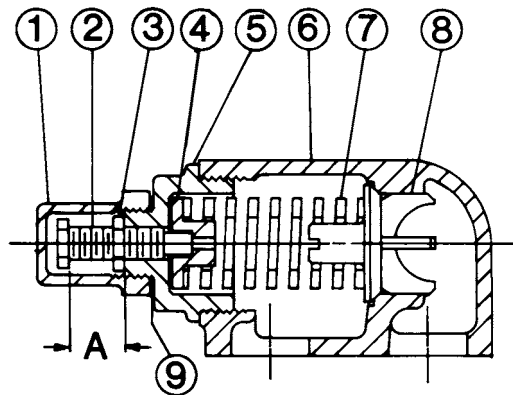

FIGURE 11

VALVE - LIST OF PARTS

- | | |
|--------------------|-----------------|
| 1. Valve Cap | 6. Valve Body |
| 2. Adjusting Screw | 7. Valve Spring |
| 3. Lock Nut | 8. Poppet |
| 4. Spring Guide | 9. Cap Gasket |
| 5. Bonnet | |

ASSEMBLY

DANGER !

Before starting pump, be sure all drive equipment guards are in place.

Failure to properly mount guards may result in serious injury or death.

Reverse the procedure outlined under **DISASSEMBLY**. If valve is removed for repairs, be sure to replace in same position. The valve cap should point towards the suction port.

PRESSURE ADJUSTMENT

CAUTION: Do not run with valve in full bypass for more than 30 seconds at a time. If a new spring is installed or if pressure setting of pressure relief valve is to be changed from that which the factory has set, the following instructions must be carefully followed.

1. Install a pressure gauge in discharge line for actual adjustment operation.
2. Carefully remove valve cap which covers adjusting screw.

Loosen locknut which locks adjusting screw so pressure setting will not change during operation of pump.
3. Turn adjusting screw in to increase pressure and out to decrease pressure.
4. With discharge line closed at a point beyond pressure gauge, gauge will show maximum pressure valve will allow while pump is in operation.

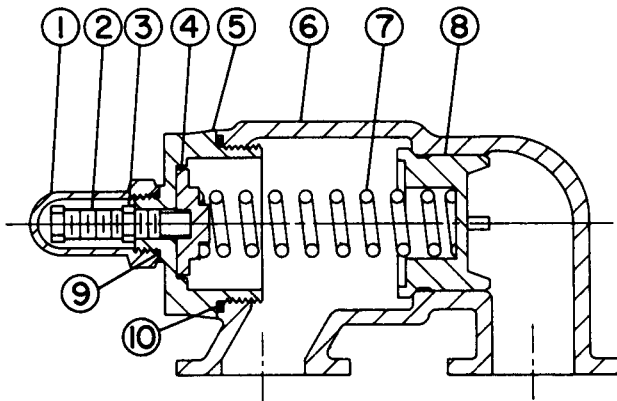

FIGURE 12

VALVE - LIST OF PARTS

1. Valve Cap	6. Valve Body
2. Adjusting Screw	7. Spring
3. Lock Nut	8. Poppet
4. Spring Guide	9. Cap Gasket
5. Bonnet	10. Bonnet Gasket

IMPORTANT

In ordering parts for relief valve on head, always be sure to give Model and Serial Number of pump as it appears on name plate and the name of the part wanted. When ordering springs, be sure to give the pressure setting desired.

VIKING PUMP

IDEX

IDEX CORPORATION

WARRANTY

Viking warrants all products manufactured by it to be free from defects in workmanship or material for a period of one (1) year from date of startup, provided that in no event shall this warranty extend more than eighteen (18) months from the date of shipment from Viking. If, during said warranty period, any products sold by Viking prove to be defective in workmanship or material under normal use and service, and if such products are returned to Viking's factory at Cedar Falls, Iowa, transportation charges prepaid, and if the products are found by Viking to be defective in workmanship or material, they will be replaced or repaired free of charge, FOB. Cedar Falls, Iowa.

Viking assumes no liability for consequential damages of any kind and the purchaser by acceptance of delivery assumes all liability for the consequences of the use or misuse of Viking products by the purchaser, his employees or others. Viking will assume no field expense for service or parts unless authorized by it in advance.

Equipment and accessories purchased by Viking from outside sources which are incorporated into any Viking product are warranted only to the extent of and by the original manufacturer's warranty or guarantee, if any.

THIS IS VIKING'S SOLE WARRANTY AND IS IN LIEU OF ALL OTHER WARRANTIES, EXPRESSED OR IMPLIED, WHICH ARE HEREBY EXCLUDED, INCLUDING IN PARTICULAR ALL WARRANTIES OF MERCHANTABILITY OR FITNESS FOR A PARTICULAR PURPOSE. No officer or employee of IDEX Corporation or Viking Pump, Inc. is authorized to alter this warranty.