

DRAWING NO.
AV-620

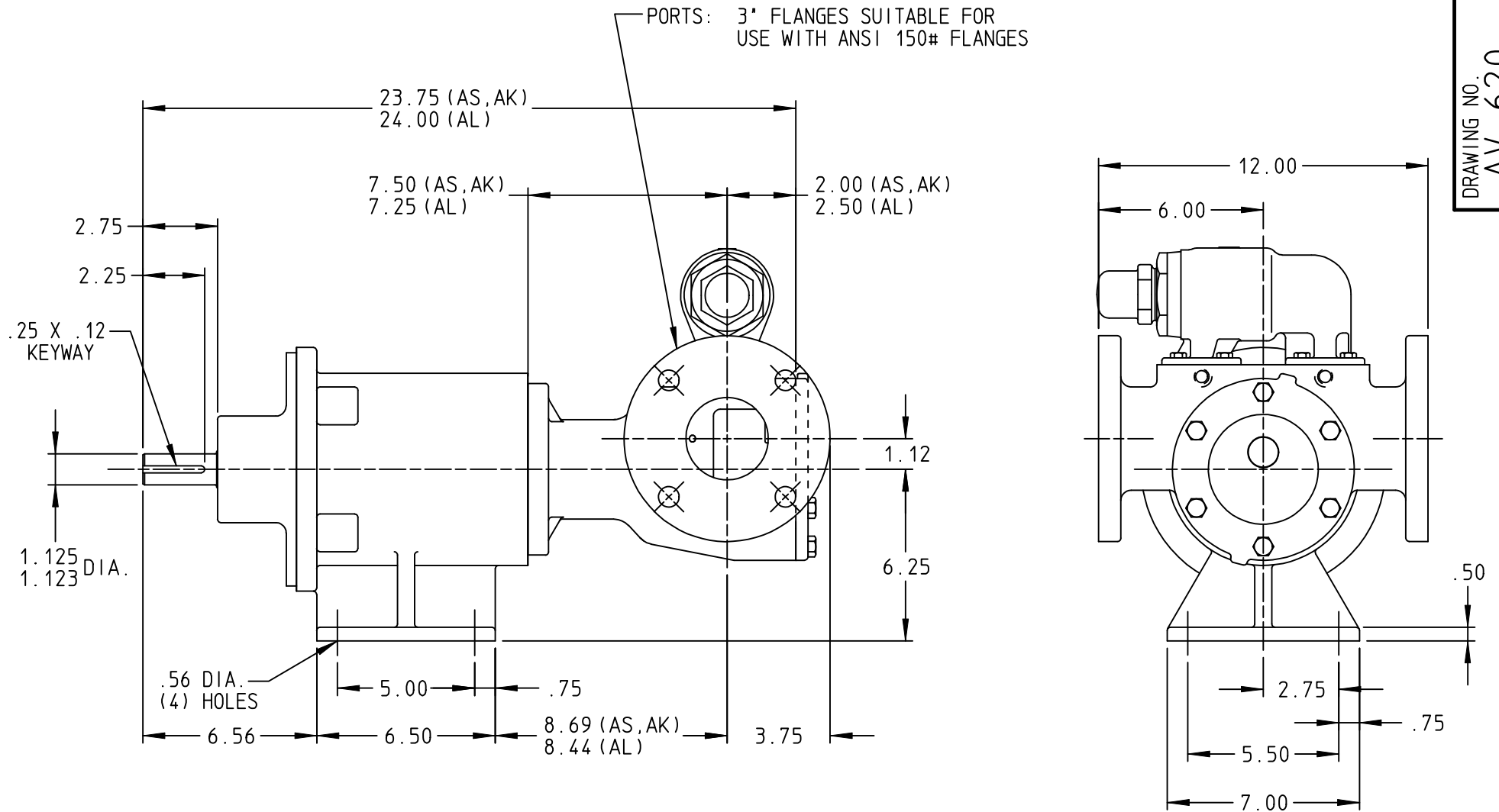

STANDARD MODELS: AS 897 MD-B15 B, AK 897 MD-B15 B, AL 897 MD-B15 B
AS 897 MD-B40 B, AK 897 MD-B40 B, AL 897 MD-B40 B

DRAWN JAKEL DATE 02 OCT 1989
CHECKED DC DATE 02 OCT 1989

THIS DRAWING IS THE PROPERTY OF VIKING PUMP INC. AND IS PROPRIETARY IN GENERAL AND DETAIL. IT SHALL NOT BE COPIED OR ITS CONTENTS REVEALED TO OUTSIDE PARTIES WITHOUT THE WRITTEN CONSENT OF VIKING PUMP INC.

VIKING PUMP

VIKING PUMP, INC.
A Unit of IDEX Corporation
Cedar Falls, Iowa 50613
U.S.A.

DRAWING NO.
AV-620

REV. C
02 OCT 1989